

80GHz Radar Level Transmitter

User's Manual (Ver: 1.0)

 Shaanxi 01000373

 13L169-61

Shaanxi ShengKe Electronic Technology Co., Ltd

1. Warranty and service scope.....	1
2. Unpacking inspection and precautions.....	2
2.1 Unpacking inspection.....	2
2.2 Precautions.....	2
3. Storage and transportation.....	3
3.1 Storage conditions.....	3
3.2 Transporting the device.....	3
4. Product description.....	4
4.1 Product overview.....	4
4.2 Technical parameters.....	4
4.3 Scope of application.....	5
4.3.1 Medium.....	5
4.3.2 Ambient temperature.....	5
4.3.3 Explosion-proof and protection level.....	5
5. Shape structure and Graph.....	6
5.1 Shape Structure.....	6
5.2 Graph.....	6
6. Interface.....	7
7. Parameter setting and interface.....	7
7.1 Parameter setting.....	7
7.2 LCD main interface description.....	9
7.3 LCD wave interface description.....	9
7.4 Parameter menu.....	10
7.4.1 User parameter menu description.....	10
7.4.2 User Parameter setup scope and definition.....	11
8. Installation and debugging.....	12
8.1 Preparation prior to installation.....	12
8.2 Installation location.....	12
8.3 Software configuration instructions.....	14
9. Maintenance and repair.....	16
10. Fault handling.....	17
11. Model selection.....	18

1. **Warranty and service scope**

The radar level transmitter comes with a one-year warranty starting from the shipment date, and repair and maintenance are guaranteed for six months. This warranty is limited to the original purchaser or the user of the designated dealer and does not apply to any damage caused by human factors, including misuse, alteration, negligence, accident, or use under abnormal conditions.

Free repairs are provided for any faulty radar level transmitter returned within the warranty. To claim service under warranty, please contact our after-sales service department and attach a description of the defect. Following authorization by company representatives, please post your radar level transmitter to our after-sales service department.

If the warranty of your radar level transmitter has expired or the malfunction was caused by misuse, modification, negligence, accident, or use under abnormal conditions, a quote will be provided according to the relevant maintenance fee standard, and maintenance will be carried out following customer approval. After the radar level transmitter is repaired, it will be mailed back to the customer, who will be required to pay for the repair and transportation costs. (Attached: Warranty Form)

2. Unpacking inspection and precautions

2.1 Unpacking inspection

- User's manual
- Certificate
- Packing list
- Radar level transmitter
- Verify the name, model, etc. on the nameplate
- Ensure the shell is in good condition and the glass window cover is intact
- Check the enclosed items against the packing list

Check whether the specifications, model and accessories are correct and complete according to the packing list. If you have any questions, please contact the customer service center for assistance.

2.2 Precautions

- Please read this manual in its entirety before installation.
- Modifications due to product upgrades will not be indicated, please refer to the actual product.

3. Storage and transportation

3.1 Storage conditions

- Permissible storage temperature: $-40\sim+60$ °C
- Store the device in its original packaging.

3.2 Transporting the device

- Transport the device to the measuring location in its original packaging.
- Avoid exposure to collision, moisture, and chemical corrosion during transportation and storage.

4. Product description

4.1 Product overview

This 76-81GHz frequency modulated continuous wave (FMCW) radar device (also called millimeter wave radar) uses millimeter wave bands with frequencies higher than Ku-band radar, long-distance imaging, and multi-spectral imaging in remote target detection and environments with considerable smoke and dust. Compared to microwave radar, it can detect smaller targets and achieve more precise positioning, with higher resolution and greater accuracy.

As a 78GHz band radar used in the industrial measurement field, it provides high-precision, non-contact level and liquid level measurement. The device offers the unparalleled advantages of other ordinary microwave pulse radars and guided wave radars, with a narrower beam and more effective penetrating ability. It can adapt to ultra-complex working conditions without compromising measurement performance.

4.2 Technical parameters

Model	Two-wire system
Measuring range	10m,20m,30m,50m
Measurement error	±1‰FS、±2‰FS、±5‰FS
Migration	±9.9m
Signal output	4~20mA、HART、Modbus
Power supply	DC 24V (22V~30V)
Ambient temperature	-20°C~+70°C
Ambient humidity	(0%~95%) RH
Explosion-proof mark	ExdiaIICT6 GB
Protection level	IP66
Display	128×64 LCD

Electrical Interface	M20×1.5 (F)
Weight	1.2kg
Size	Diameter:96mm×Height:221mm
Mounting hole thread	G2

4. 3 Scope of application

4. 3. 1 Medium

In general, the dielectric constant of the measured medium must be greater than 2 to ensure sufficient reflection.

4. 3. 2 Ambient temperature

The ambient temperature range is $-20^{\circ}\text{C} \sim +70^{\circ}\text{C}$. It is recommended to apply the instrument protection box. In areas with intense direct sunlight, install the instrument in a cool place or use a sun visor to avoid excessive heating and to provide good ventilation and heat dissipation.

4. 3. 3 Explosion-proof and protection level

The radar level transmitter is explosion-proof, featuring aluminum alloy casting and sealing with surface epoxy spray. Suitable for harsh environments containing explosive mixed gases, medium-concentration corrosive gases and a 0-95% humidity range.

Explosion-proof grade: ExdiaIICT6 GB。

Waterproof and dustproof grade: IP66。

5. Structure and graph

5.1 Structure

- The radar level transmitter structure is shown in Figure 1 below.

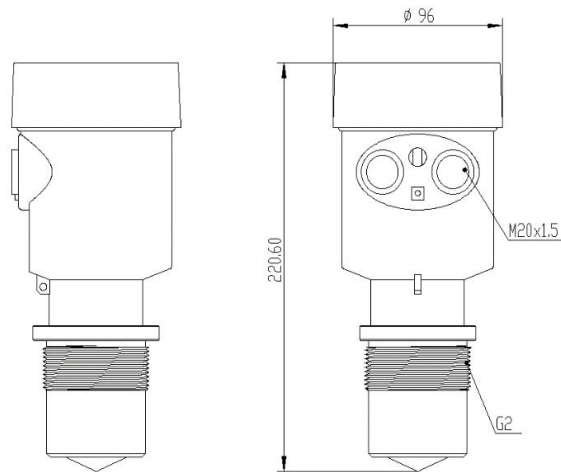

Figure 1: Radar level transmitter structure

5.2 Graph

The radar level transmitter physical graph is shown in Figure 2 below.



Figure 2: Transmitter physical graph

6. Interface

The radar level transmitter interface is shown in Figure 3 below.

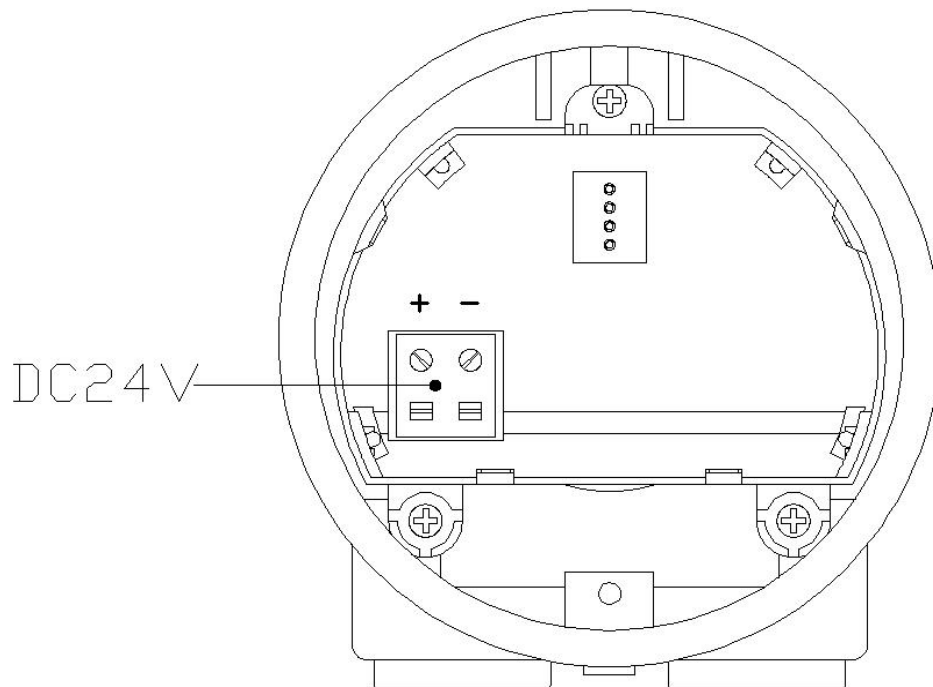

Figure 3: Transmitter interface

- **Interface description**

Interface	Description
PIN1	24VDC(+)Power supply positive
PIN2	24VDC(-)Power supply negative

7. Parameter settings and interface

7.1 Parameter settings

The radar level transmitter uses various keys to control the parameter settings, and the interface

is shown in Figure 4 below.



Figure 4: Parameter keys

Key function:

Key	Function
ESC	Back / Enter echo wave interface
UP ARROW	Up shift/ Increase key
DOWN ARROW	Down shift / Decrease key
OK	Ok key / Enter setting parameter interface

7. 2LCD main interface description

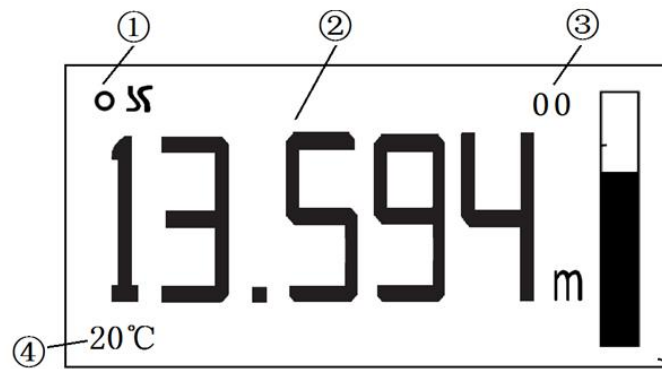

Figure 5: LCD main interface

①	Work in progress	Flashing reminder when in operation
②	Level display	Level value (m/mm/cm/ft/ft)
③	Error code	00: No error (does not show error) 01: No target detected 02: Level value jumped 08: Communication error
④	Temperature	Displays the temperature value when the temperature display function is turned on.

7. 3LCD wave interface description

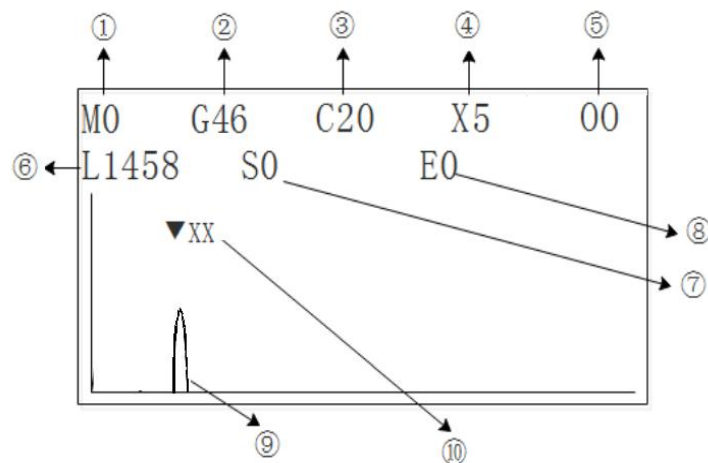

Figure 6: LCD wave interface

①	Gain mode (0: Automatic; 1: Fixed)
②	Gain
③	Filter coefficient (greater than 0, less than 100)
④	Signal to noise ratio (1-99)
⑤	Error code
⑥	Real time measurement value (Ullage, Unit: mm)
⑦	The starting position of the waveform display Sxxxxx (Unit: mm)
⑧	The ending position of the waveform display Sxxxxx (Unit: mm) Exxxxx (Unit: mm)
⑨	Waveform
⑩	Wave location

7. 4 Parameter menu

7. 4. 1 User parameter menu description

User Para	Basic setup	Range
		Offset
		Show Type
		Pos:4ma
		Pos:20ma
		Blind
		Damping Time
		Device ID
		Baud Rate
	Backup Para	
Restore Para		

7. 4. 2 User parameter setup scope and definition

- **Basic setup:**

Range (500~50000) mm: Indicates the farthest distance that the radar can measure, depending on the operating conditions.

Offset (-9999~9999) mm: Depends on the operating conditions.

Show Type: Displays level value/ullage value.

(Pos:4ma): Level corresponding to 4mA current output; unit: mm。

(Pos:20ma): Level corresponding to 20mA current output; unit: mm。

Blind: The value range is 230mm to the measuring range, which can be set according to the specific operating conditions.

Damping time: A larger damping time can be set to stabilize the measured output value and increase the anti-interference ability. For example, if the damping time is 10, the measured level changes step by step at time t, and the measured output value will follow the actual position of the measured object after 10 seconds.

Device ID : The address during 485 communications, that is, the address of the local machine (value range: 1-99; the default value is 1).

Baud rate: The default baud rate of the device during 485 communications is 9600.

- **Backup Parameter:**

Once the working parameters are backed up, you can choose to restore them from the menu after modifying.

- **Restore Parameter:**

Used to restore the backed up user parameters.

8. Installation and debugging

8.1 Preparation prior to installation

- Familiarize yourself with the internal structure and pipeline arrangement of the storage tank, and obtain the necessary figures such as the tank's diameter and range.
- Tools needed: flat-blade screwdriver (3*75mm), wire stripper (7mm²), hand knife, pipe wrench, DC 24V power supply.
- After gathering the necessary tools, unpack the box and consult the packing list to ensure the materials are complete.

8.2 Installation location

Avoid installing the radar level transmitter at the center or edge of the container to prevent false readings.

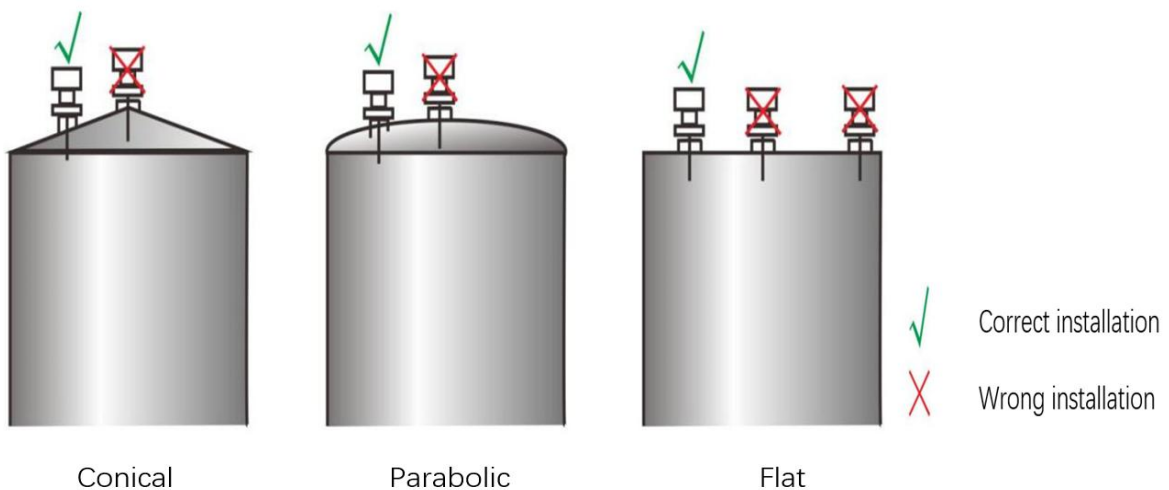
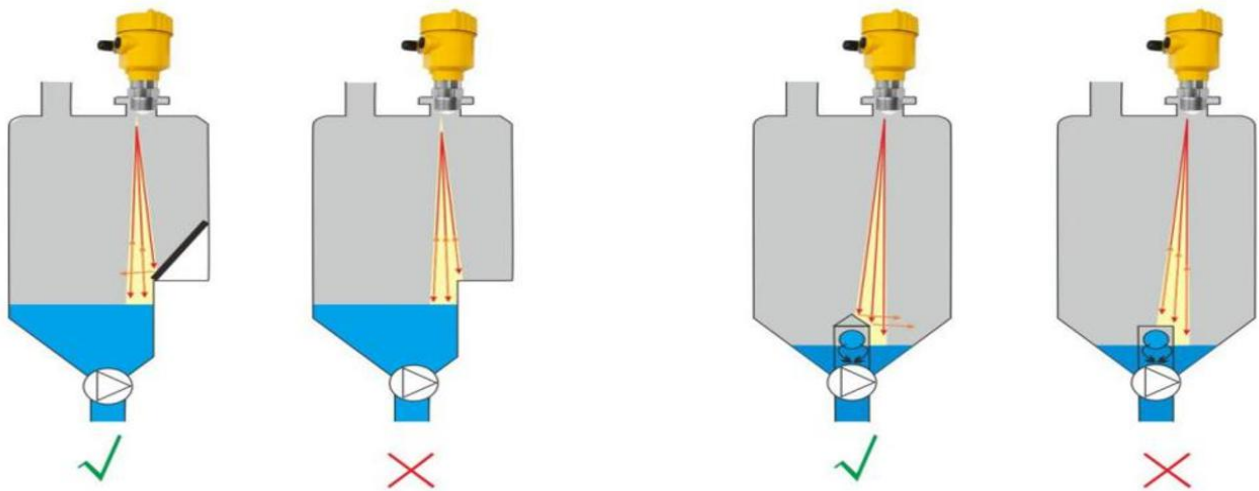

Figure 7: Radar installation location diagram

- Avoid producing a false wave.



Avoid false wave examples

Figure 8: False wave examples

- Properly manage stairs and grille tanks.

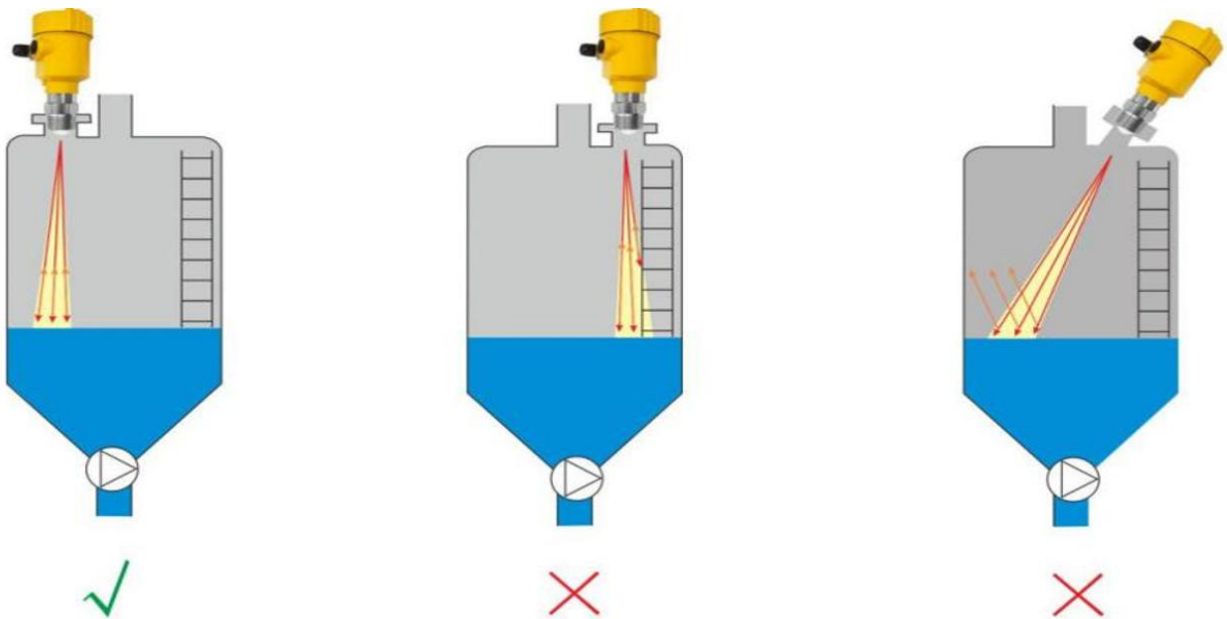

Treatment of stairs and grille tanks

Figure 9: Treatment of stairs and grille tanks

- Properly manage wall hanging and grille tanks.

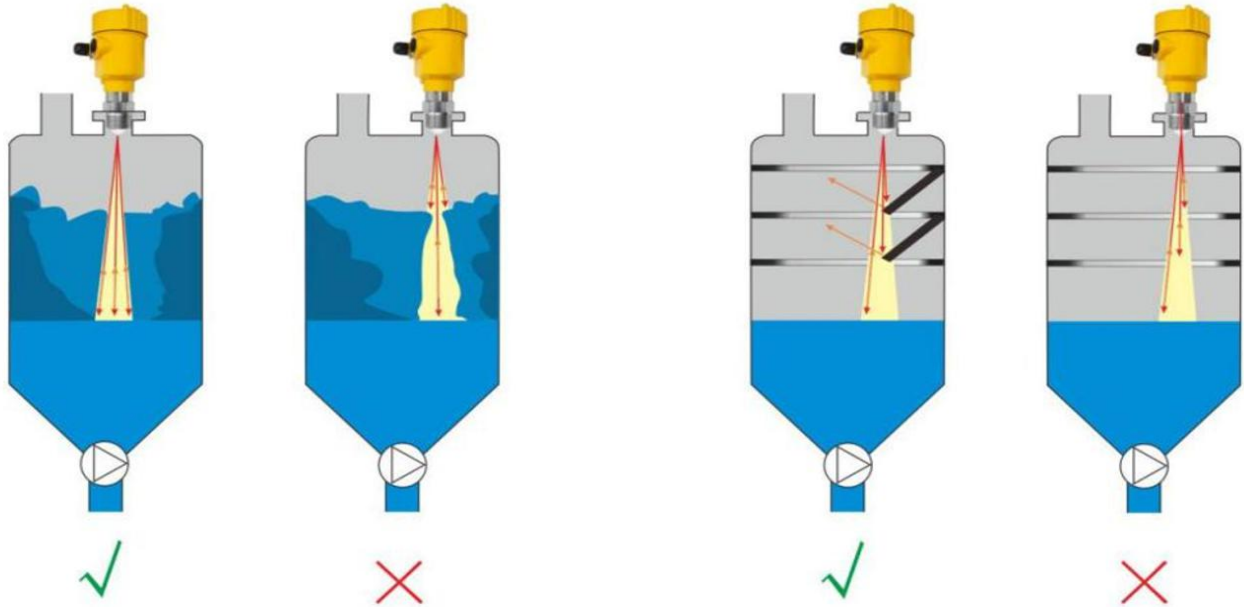

Treatment of wall hanging and grille tanks

Figure 10: Treatment of wall hanging and grill tanks

8.3 Software configuration instructions

- **Instrument connection**

The power cord is connected to the device's DC 24V terminal. Please carefully observe the positive and negative poles and ensure they're properly connected.

- **Set instrument parameters**

Press the "OK" button on the instrument's interface; the meter will display the "Main Menu", as shown in the figure below:

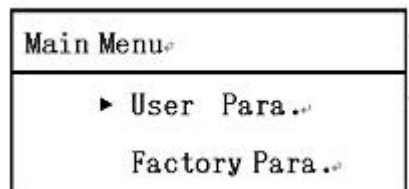

Press the "OK" button to enter the "User Para".

User Para.
▶Basic Setup
Backup Para..
Restore Para..

Press the "OK" button to enter the "Basic Setup".

Basic Setup
▶Range: 10000 mm
Offset: 0 mm
Pos 4ma: 0 mm

Basic Setup
▶ Pos 20ma: 10000 mm
Blind: 200 mm
ShowType: Level

Basic Setup
▶Damping Time: 200
DeviceID: 1
BaudRate: 9600

Set the "Range" according to the operating conditions, then press "OK". After the range value is reversed, use the "Upshift" and "Downshift" buttons to input the range value, then press the "OK" button to confirm.

Press the "Downshift" button to select "Offset", press "OK" to reverse the migration value, enter the migration value, then press "OK" to confirm.

The same steps can be used to modify "Pos:4ma"/"Pos:20ma"/"Blind"/"Damping Time". After the modification is complete, press the "Backspace" key to return to the "User Para" interface.

When the display type is set to level, the main interface shows the actual level value. When the display type is set to ullage, the main interface displays the ullage measured by the radar. Set the display type as required.

Pos:4ma and **Pos:20ma** must be within the given range. The relationship between the 4mA position, 20mA position and range is shown in the figure below:

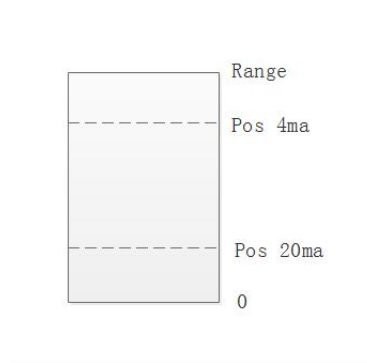

If the level is lower than **Pos:4ma**, the main interface displays the level as 0; if the level is higher than **Pos:20ma**, the main interface displays the level as **Pos:20ma**.

9. Maintenance and repair

- Please keep the radar clean and away from water, moisture, corrosion and collisions with other objects.
- Please keep the main body of the transmitter away from direct sunlight and heat sources and ensure proper ventilation. If the ambient temperature exceeds the rated temperature, take appropriate cooling measures to avoid overheating.
- If the ambient temperature is too low, use an instrument protection box or other protective device against freezing, and make sure to keep the radar dry.
- The radar should be regularly inspected to ensure proper functioning; inspect more often if exposed to extreme operating conditions.

10. Fault handling

Appearance	Reason	Solution
No display	Power supply error	Check whether the DC 24V voltage and current meet the requirements.
	Wiring error	Verify that the wiring is correct.
Value unstable	Too much fluctuation	Change the radar's installation position or reduce the fluctuation of the object to be measured.
	Weak signal	Try angle calibration or rotate the radar installation position.
	Strong electromagnetic interference	Connect the instrument to the ground or shield.

11. Model Selection

SK-R800	80GHz Radar Level Transmitter					
	Code	Medium Type				
	L	Liquid				
	S	Solid				
		Code	Measuring Range			
		3~30	10m、 15m、 30m			
			Code	Connection		
			G	G Thread		
			N	NPT Thread		
			X	Customize		
				Code	Temperature	
				N	-40-60°C	
					Code	Electric Interface
					M	M20×1.5(F)
					N	1/2 NPT(F)
					Code	Communication
					M	Modbus
					H	Hart
SK-R800	L	10	G	N	M	H

Shaanxi ShengKe Electronic Technology Co., Ltd

Website: <https://www.skgauge.com>

Tel: 029-88858601

Fax: 029-88858601

Postcode: 710000

Address: Room 1911, junminronghe building, fazhan road, Xi'an, Shaanxi, China